



REF200

ABRIDGED DATA SHEET
For Complete Data Sheet
Call Fax Line 1-800-548-6133
Request Document Number 10851

DUAL CURRENT SOURCE/CURRENT SINK

FEATURES

- COMPLETELY FLOATING:
No Power Supply or Ground Connections
- HIGH ACCURACY: $100\mu\text{A} \pm 0.5\%$
- LOW TEMPERATURE COEFFICIENT:
 $\pm 25\text{ppm}/^\circ\text{C}$
- WIDE VOLTAGE COMPLIANCE:
2.5V to 40V
- ALSO INCLUDES CURRENT MIRROR

APPLICATIONS

- SENSOR EXCITATION
- BIASING CIRCUITRY
- OFFSETTING CURRENT LOOPS
- LOW VOLTAGE REFERENCES
- CHARGE-PUMP CIRCUITRY
- HYBRID MICROCIRCUITS

DESCRIPTION

The REF200 combines three circuit building-blocks on a single monolithic chip—two $100\mu\text{A}$ current sources and a current mirror. The sections are dielectrically isolated, making them completely independent. Also, since the current sources are two-terminal devices, they can be used equally well as current sinks. The performance of each section is individually measured and laser-trimmed to achieve high accuracy at low cost.

The sections can be pin-strapped for currents of $50\mu\text{A}$, $100\mu\text{A}$, $200\mu\text{A}$, $300\mu\text{A}$ or $400\mu\text{A}$. External circuitry can be used to obtain virtually any current. These and many other circuit techniques are shown in the Applications section of this Data Sheet.

The REF200 is available in plastic 8-pin mini-DIP and SOIC packages.

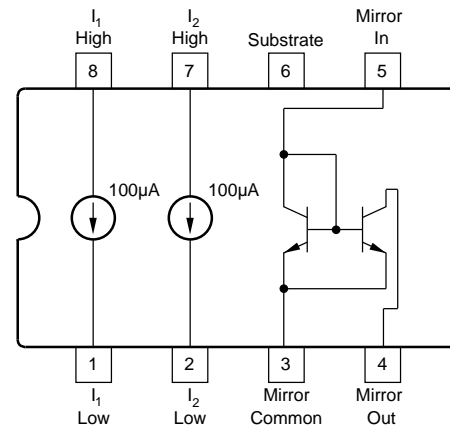

SPECIFICATIONS

ELECTRICAL

T_A = +25°C, V_S = 15V unless otherwise noted.

PARAMETER	CONDITION	REF200AP, AU			UNITS
		MIN	TYP	MAX	
CURRENT SOURCES					
Current Accuracy			±0.25	±1	%
Current Match			±0.25	±1	%
Temperature Drift	Specified Temp Range		25		ppm/°C
Output Impedance	2.5V to 40V	20	100		MΩ
	3.5V to 30V	200	500		MΩ
Noise	BW = 0.1Hz to 10Hz		1		nAp-p
	f = 10kHz		20		pA/√Hz
Voltage Compliance (1%)	T _{MIN} to T _{MAX}		See Curves		
Capacitance			10		pF
CURRENT MIRROR	I = 100μA Unless Otherwise Noted				
Gain		0.995	1	1.005	
Temperature Drift			25		ppm/°C
Impedance (output)	2V to 40V	40	100		MΩ
Nonlinearity	I = 0μA to 250μA		0.05		%
Input Voltage			1.4		V
Output Compliance Voltage			See Curves		
Frequency Response (-3dB)	Transfer		5		MHz
TEMPERATURE RANGE					
Specification		-25		+85	°C
Operating		-40		+85	°C
Storage		-40		+125	°C

PIN CONFIGURATION

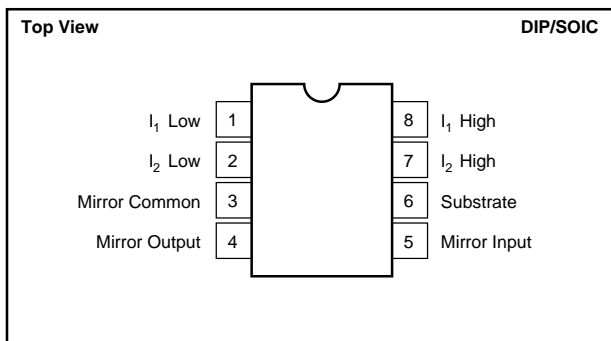

ABSOLUTE MAXIMUM RATINGS

Applied Voltage	-6V to +40V
Reverse Current	-350μA
Voltage Between Any Two Sections	±80V
Operating Temperature	-40°C to +85°C
Storage Temperature	-40°C to +125°C
Lead Temperature (soldering, 10s)	+300°C
(SOIC 3s)	+260°C

PACKAGE INFORMATION

MODEL	PACKAGE	PACKAGE DRAWING NUMBER ⁽¹⁾
REF200AP	8-Pin Plastic DIP	006
REF200AU	8-Pin SOIC	182

NOTE: (1) For detailed drawing and dimension table, please see end of data sheet, or Appendix D of Burr-Brown IC Data Book.

ORDERING INFORMATION

MODEL ⁽¹⁾	TEMPERATURE PACKAGE	RANGE
REF200AP	8-Pin Plastic DIP	-25°C to +85°C
REF200AU	8-Pin Plastic SOIC	-25°C to +85°C

NOTE: (1) Grade designation "A" may not be marked. Absence of grade designation indicates A grade.

The information provided herein is believed to be reliable; however, BURR-BROWN assumes no responsibility for inaccuracies or omissions. BURR-BROWN assumes no responsibility for the use of this information, and all use of such information shall be entirely at the user's own risk. Prices and specifications are subject to change without notice. No patent rights or licenses to any of the circuits described herein are implied or granted to any third party. BURR-BROWN does not authorize or warrant any BURR-BROWN product for use in life support devices and/or systems.

DICE INFORMATION

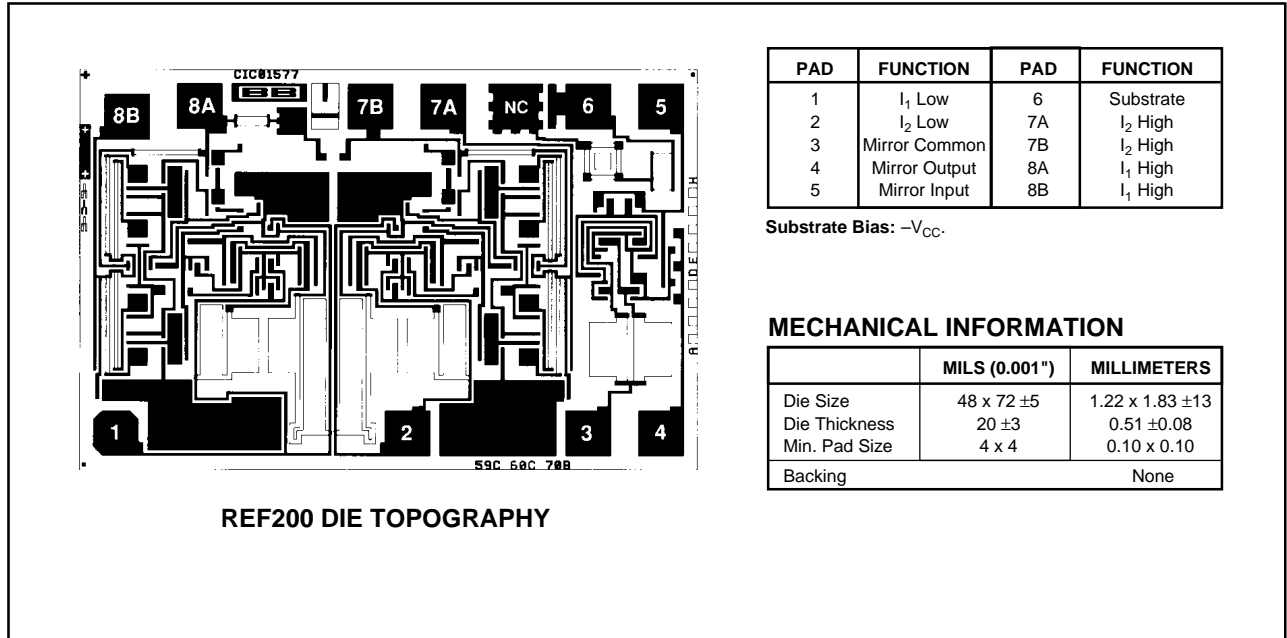

TYPICAL PERFORMANCE CURVES

$T_A = +25^\circ\text{C}$, $V_S = +15\text{V}$ unless otherwise noted.

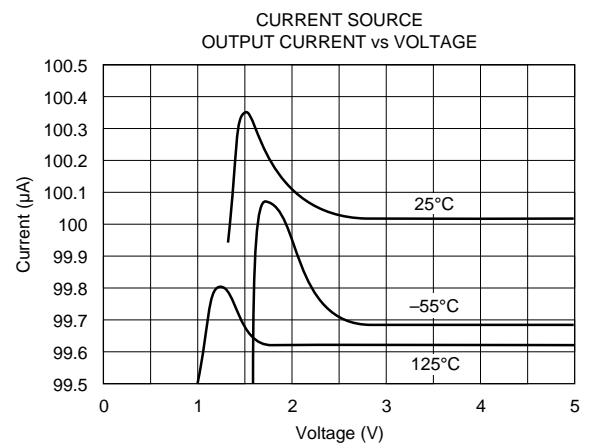
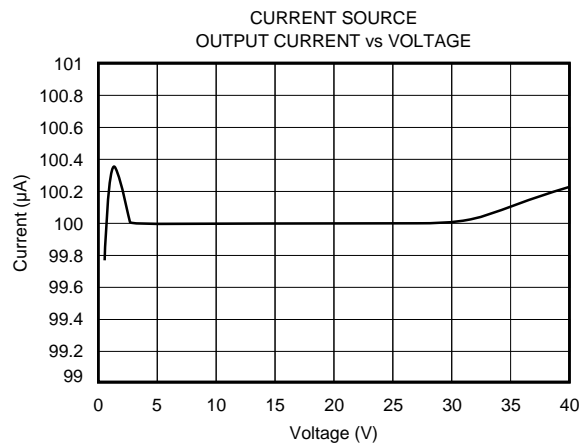
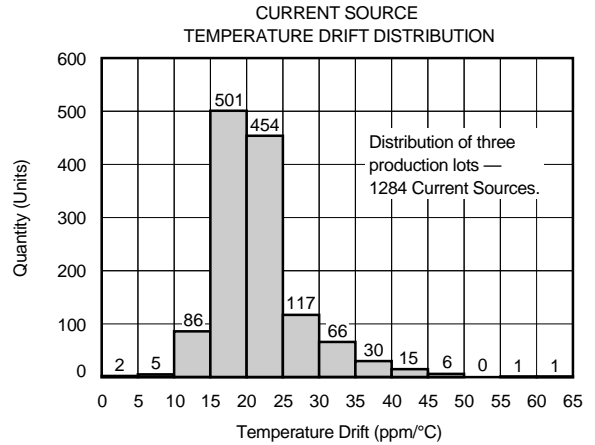
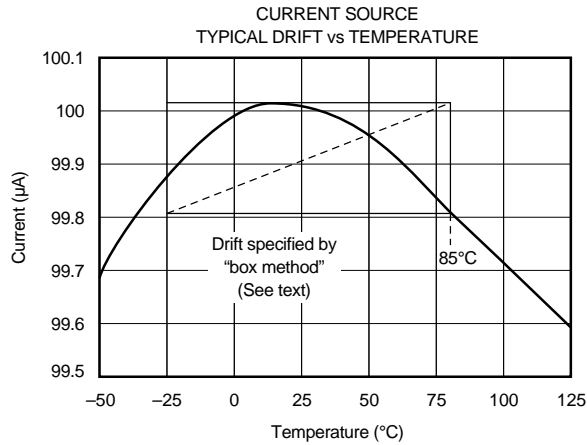

TYPICAL PERFORMANCE CURVES (CONT)

$T_A = +25^\circ\text{C}$, $V_S = +15\text{V}$ unless otherwise noted.

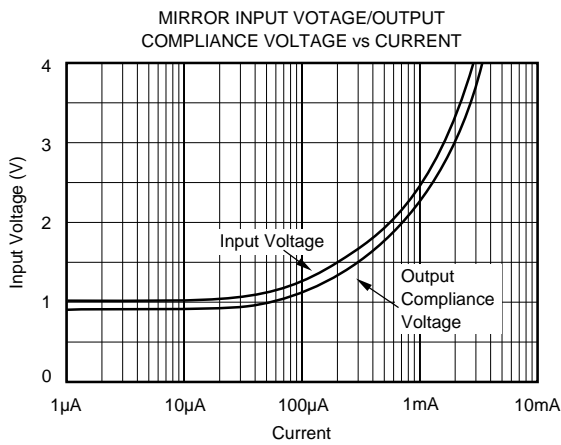
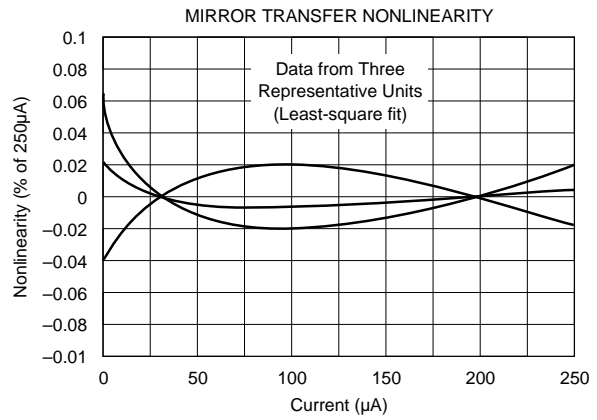
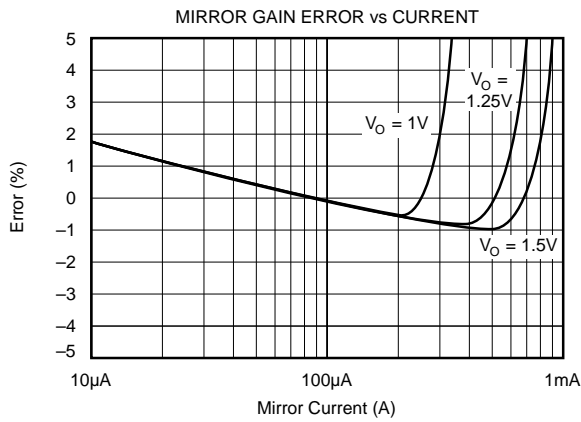
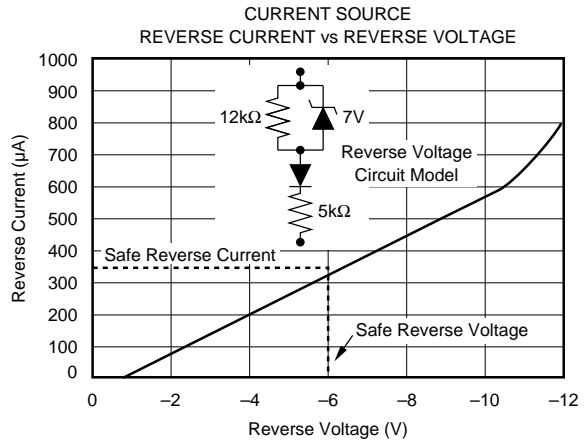
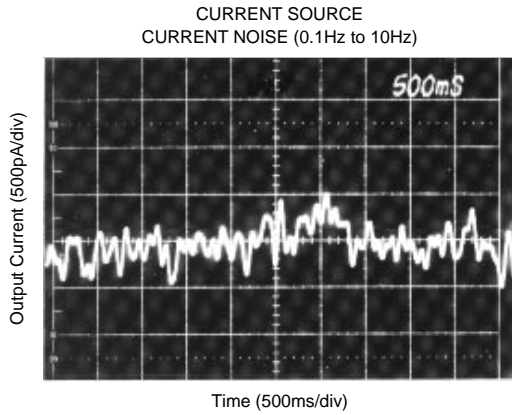

APPLICATIONS INFORMATION

The three circuit sections of the REF200 are electrically isolated from one another using a dielectrically isolated fabrication process. A substrate connection is provided (pin 6), which is isolated from all circuitry. This pin should be connected to a defined circuit potential to assure rated DC performance. The preferred connection is to the most negative constant potential in your system. In most analog systems this would be $-V_s$. For best AC performance, leave pin 6 open and leave unused sections unconnected.

Drift performance is specified by the “box method,” as illustrated in the Current vs Temperature plot of the typical performance curves. The upper and lower current extremes measured over temperature define the top and bottom of the box. The sides are determined by the specified temperature range of the device. The drift of the unit is the slope of the diagonal—typically 25ppm/°C from -25°C to $+85^{\circ}\text{C}$.

If the current sources are subjected to reverse voltage, a protection diode may be required. A reverse voltage circuit model of the REF200 is shown in the Reverse Current vs Reverse Voltage curve. If reverse voltage is limited to less than 6V or reverse current is limited to less than 350 μA , no protection circuitry is required. A parallel diode (Figure 2a) will protect the device by limiting the reverse voltage across the current source to approximately 0.7V. In some applications, a series diode may be preferable (Figure 2b) because it allows no reverse current. This will, however, reduce the compliance voltage range by one diode drop.

Applications for the REF200 are limitless. Application Bulletin AB-165 shows additional REF200 circuits as well as other related current source techniques. A collection of circuits is shown to illustrate some techniques. Also, see AB-165A.

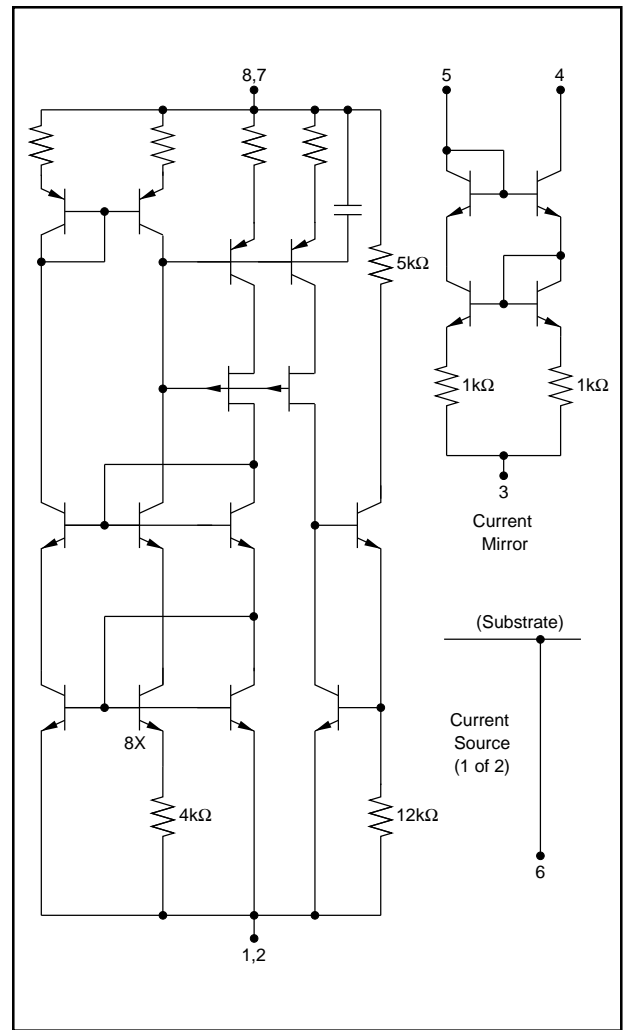

FIGURE 1. Simplified Circuit Diagram.

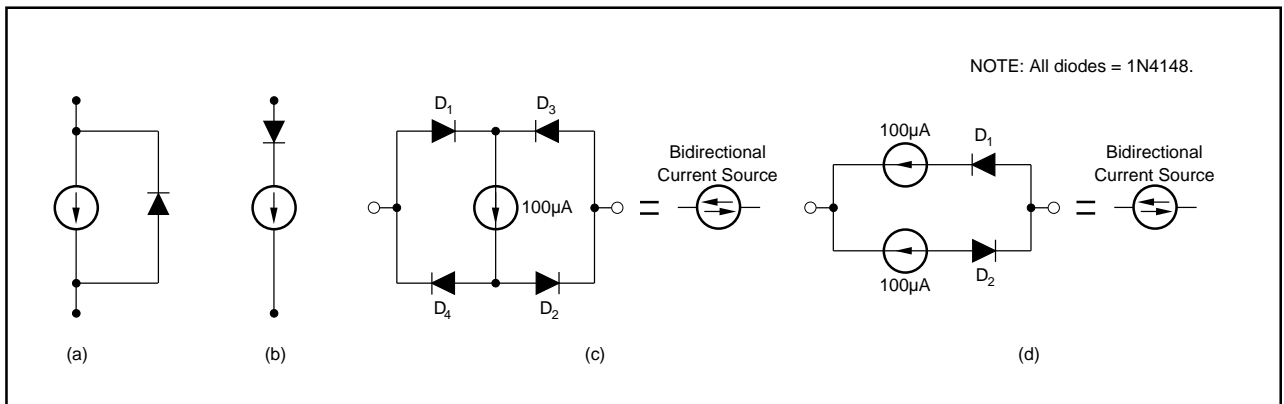

FIGURE 2. Reverse Voltage Protection.

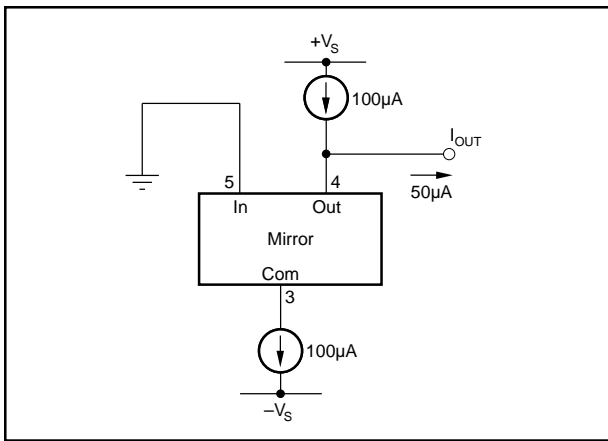

FIGURE 3. 50µA Current Source.

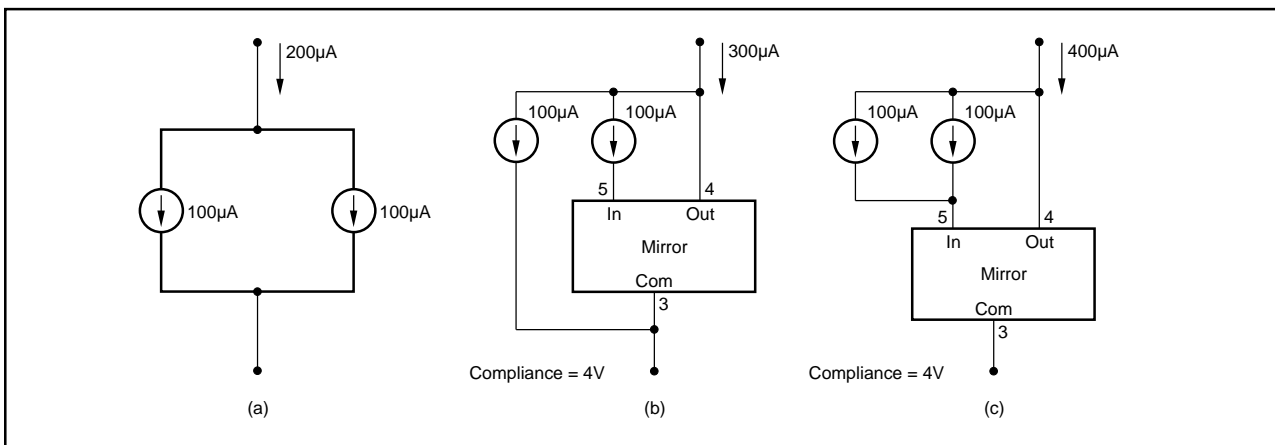

FIGURE 4. 200µA, 300µA, and 400µA Floating Current Sources.

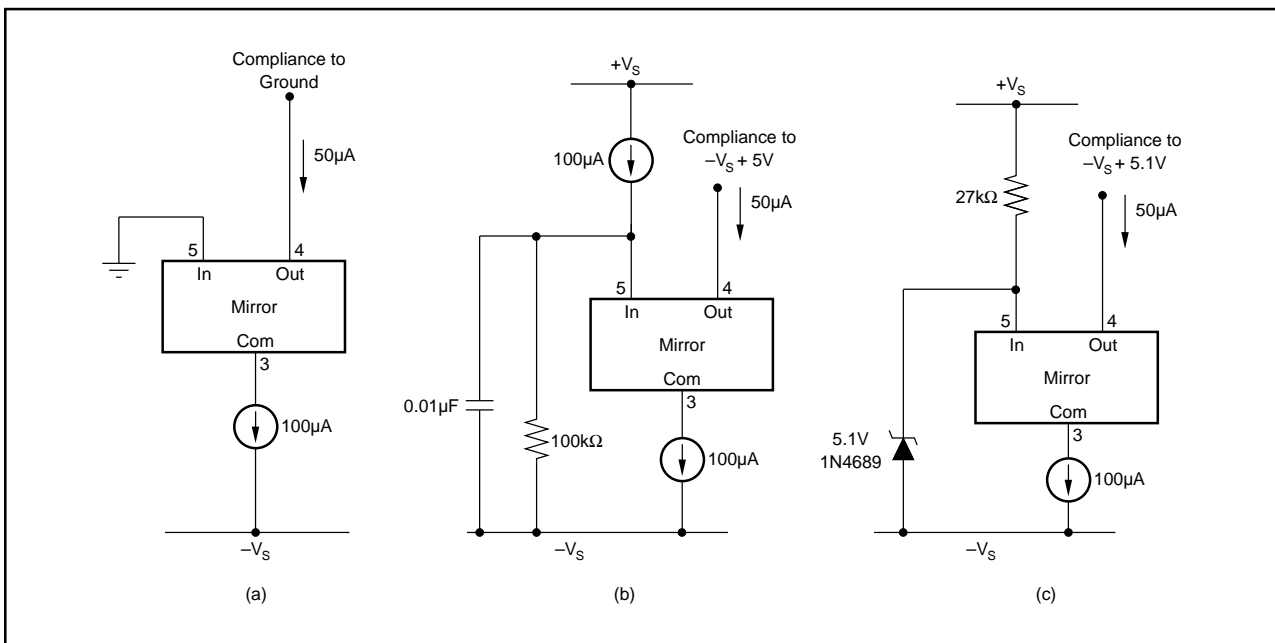

FIGURE 5. 50µA Current Sinks.

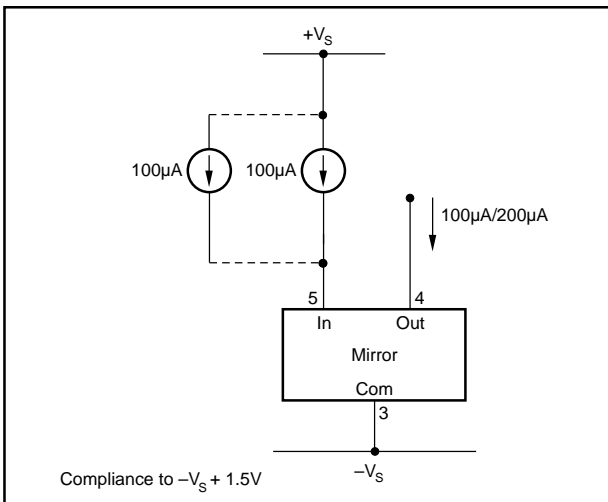

FIGURE 6. Improved Low-Voltage Compliance.

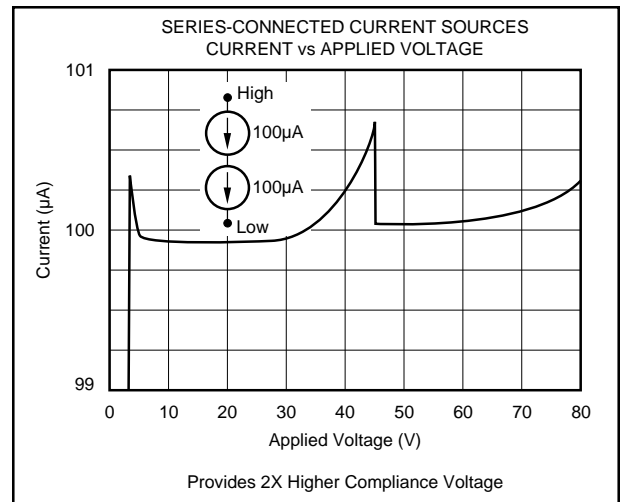

FIGURE 7. 100µA Current Source—80V Compliance.

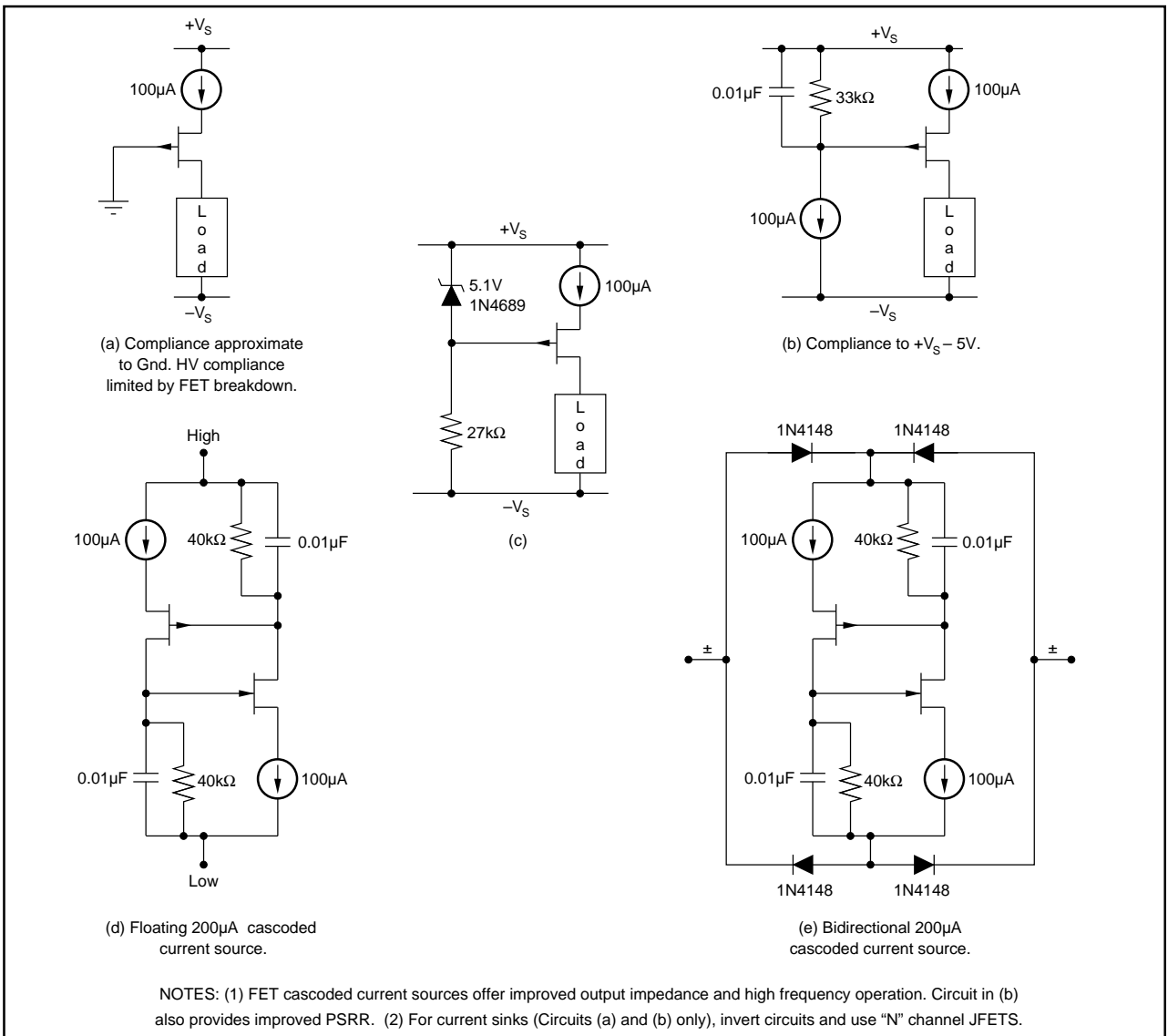

FIGURE 8. FET Cascode Circuits.

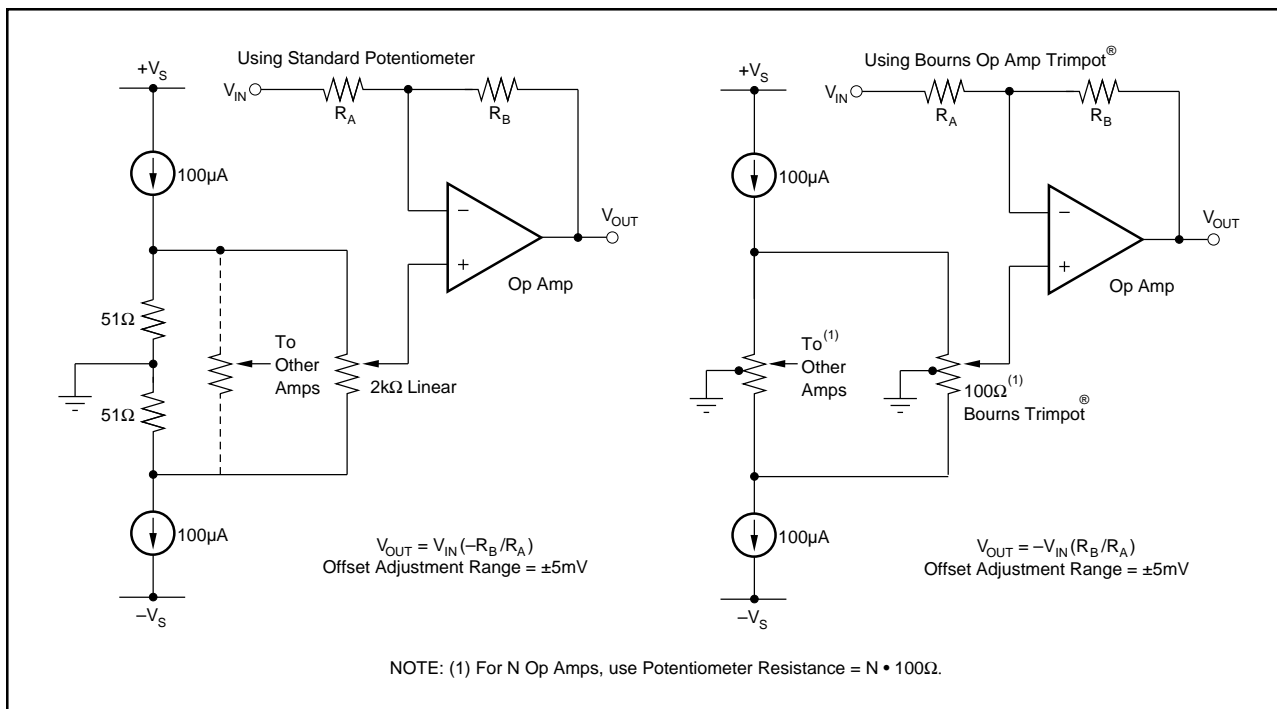

FIGURE 9. Op Amp Offset Adjustment Circuits.

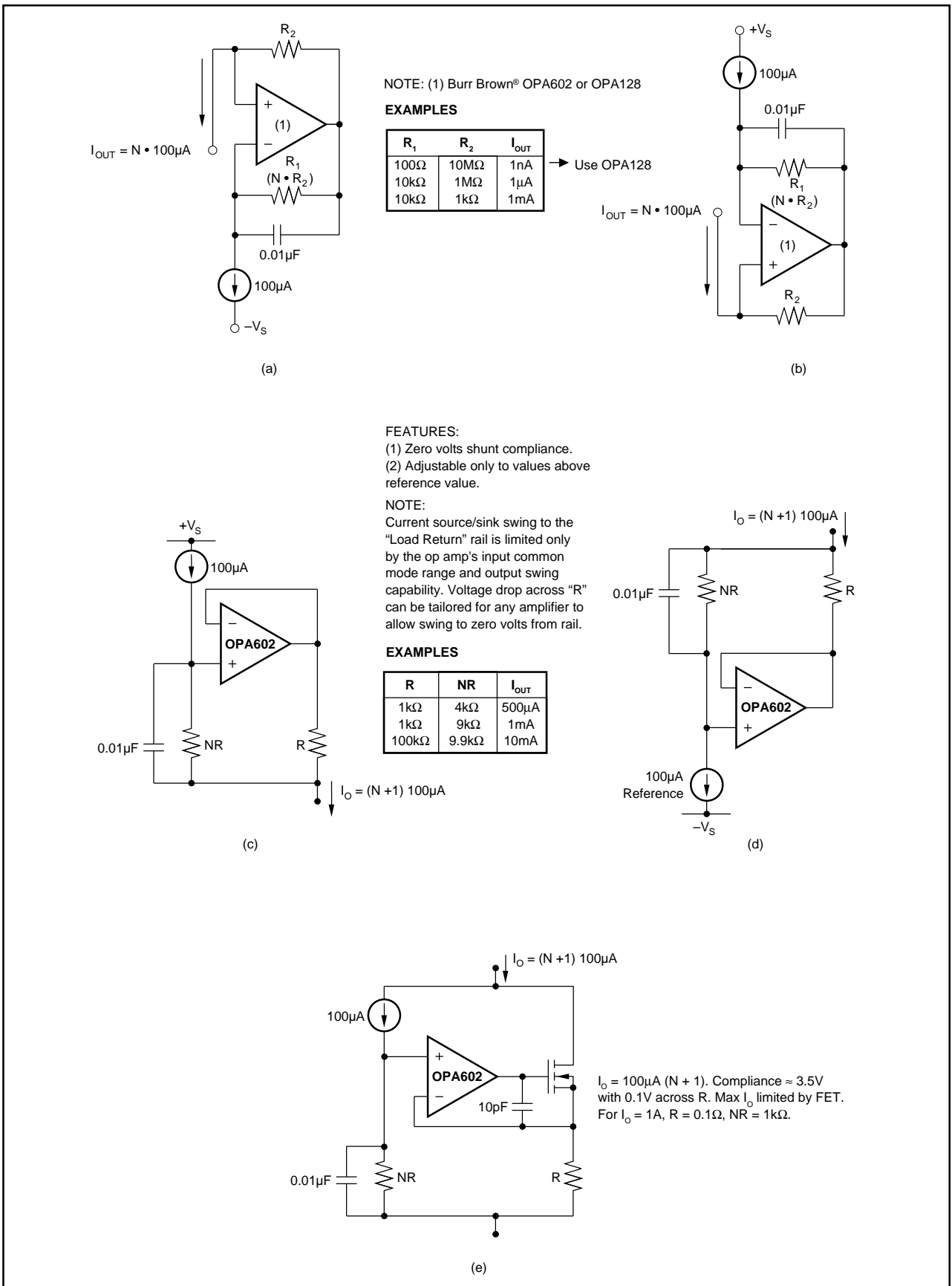

FIGURE 10. Adjustable Current Sources.

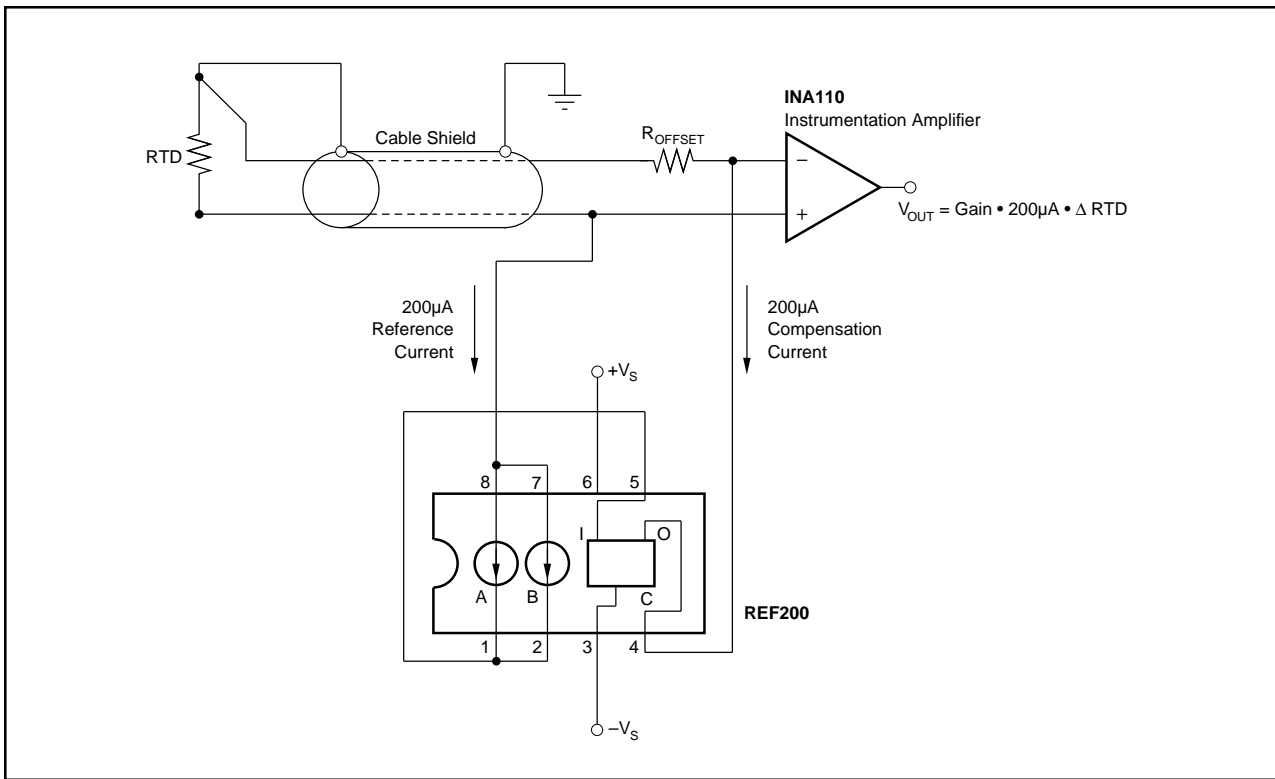

FIGURE 11. RTD Excitation With Three Wire Lead Resistance Compensation.

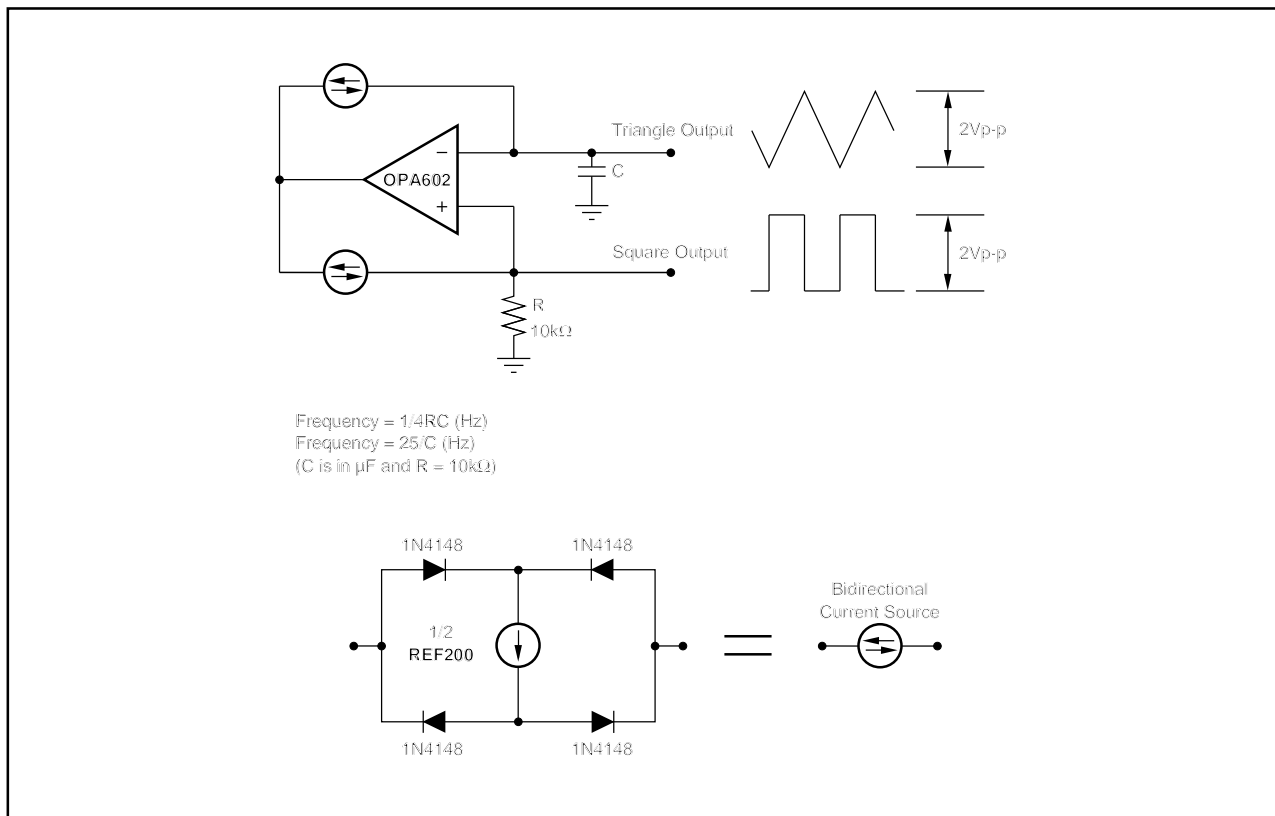

FIGURE 12. Precision Triangle Waveform Generator.

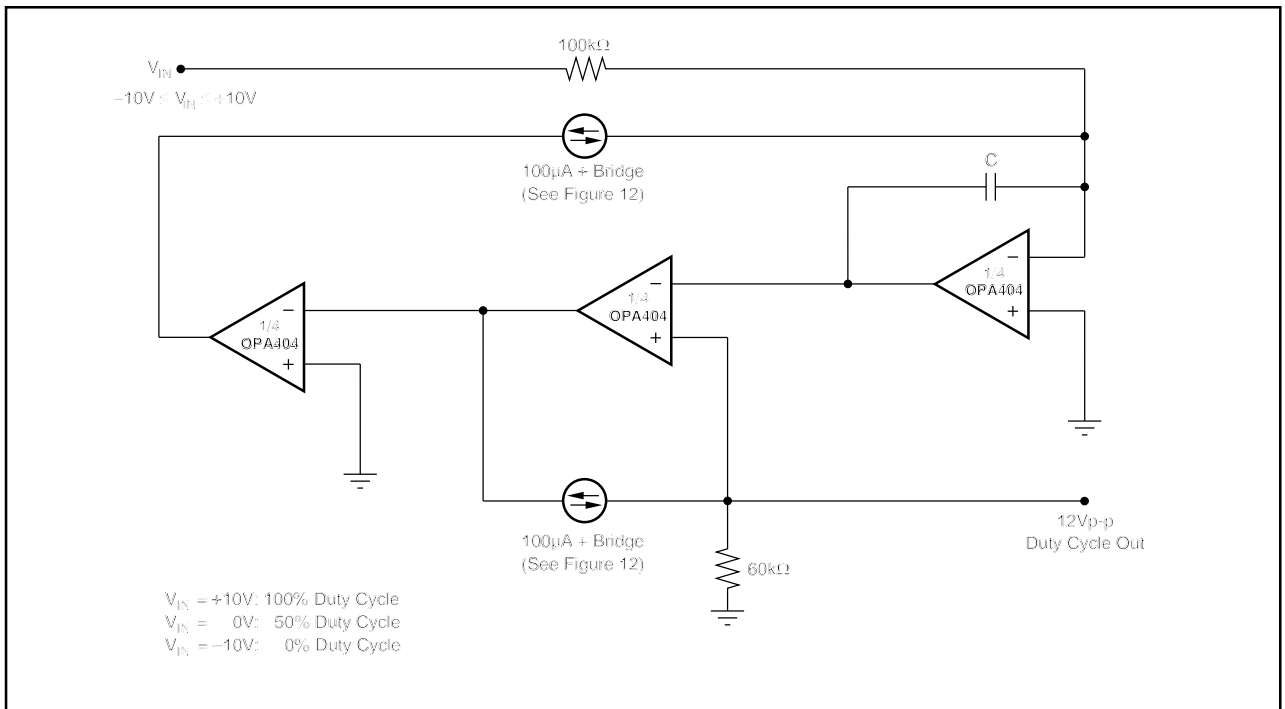

FIGURE 13. Precision Duty-Cycle Modulator.

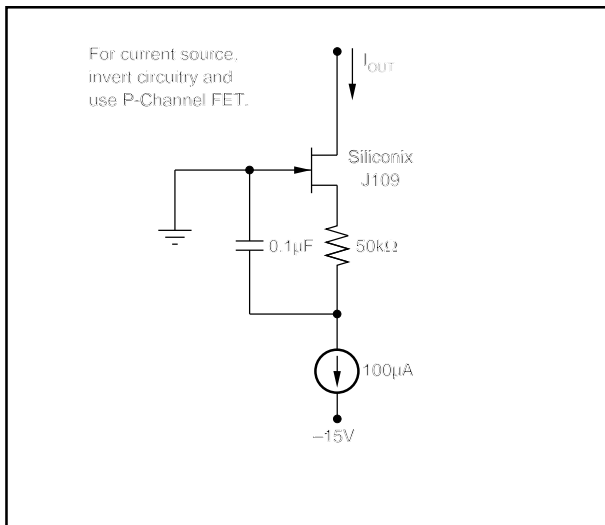

FIGURE 14. Low Noise Current Sink.

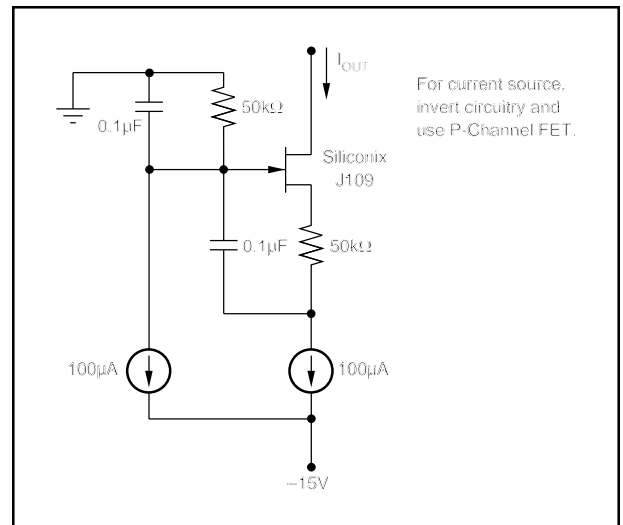

FIGURE 15. Low Noise Current Sink with Compliance Below Ground.

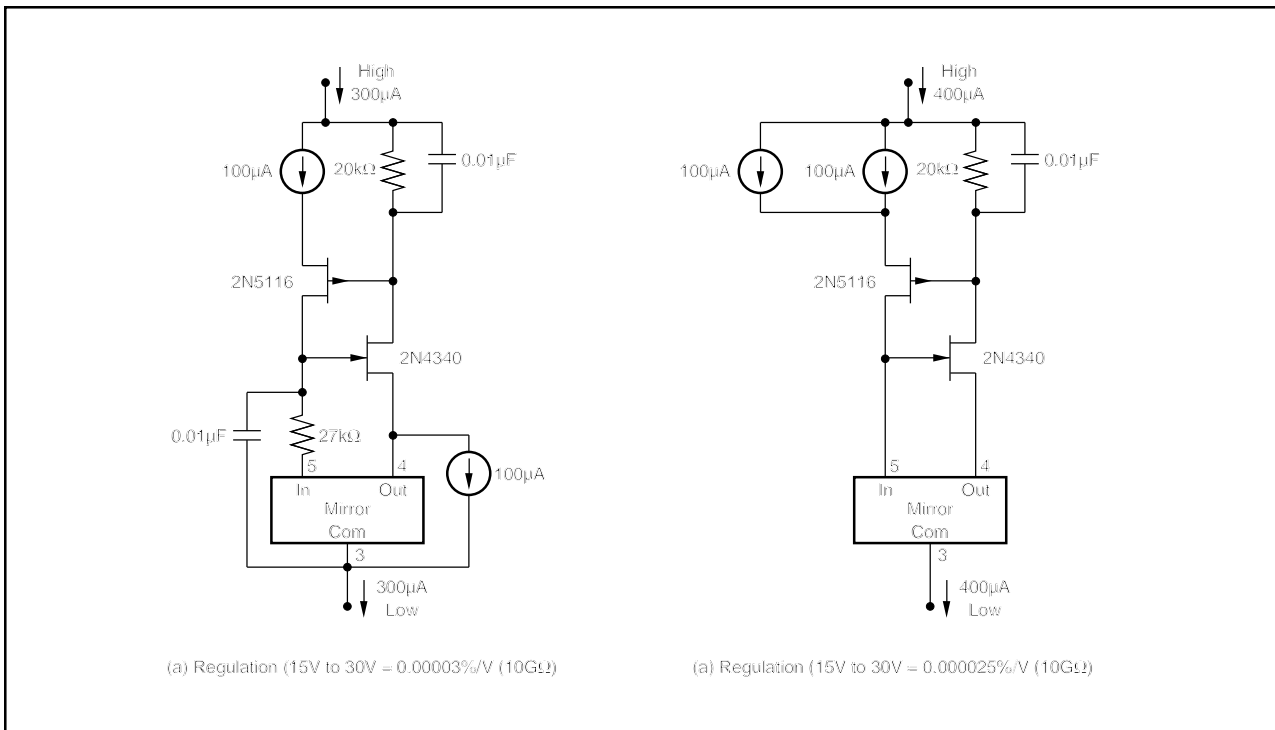

FIGURE 16. Floating 300µA and 400µA Cascoded Current Sources.

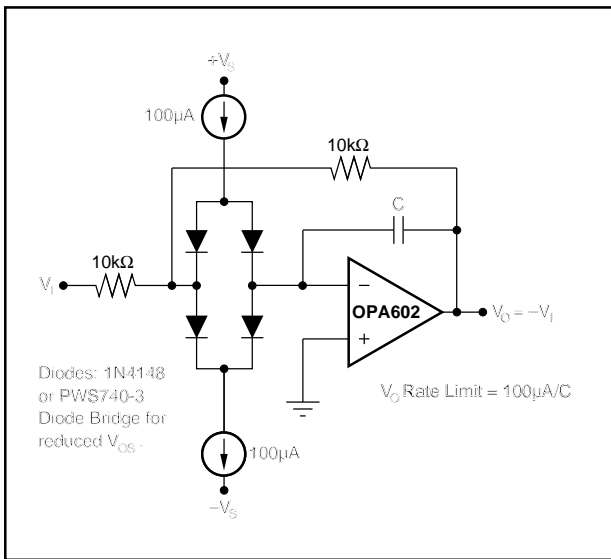

FIGURE 17. Rate Limiter.

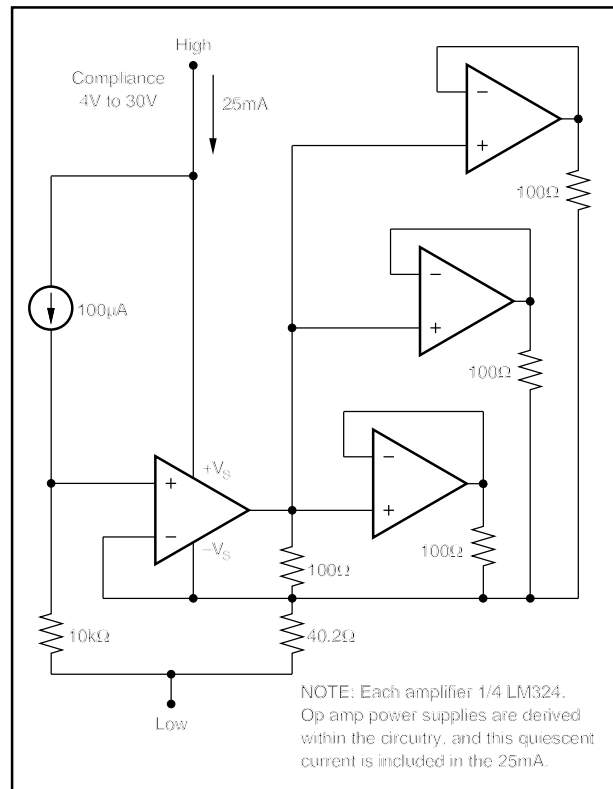

FIGURE 18. 25mA Floating Current Source.

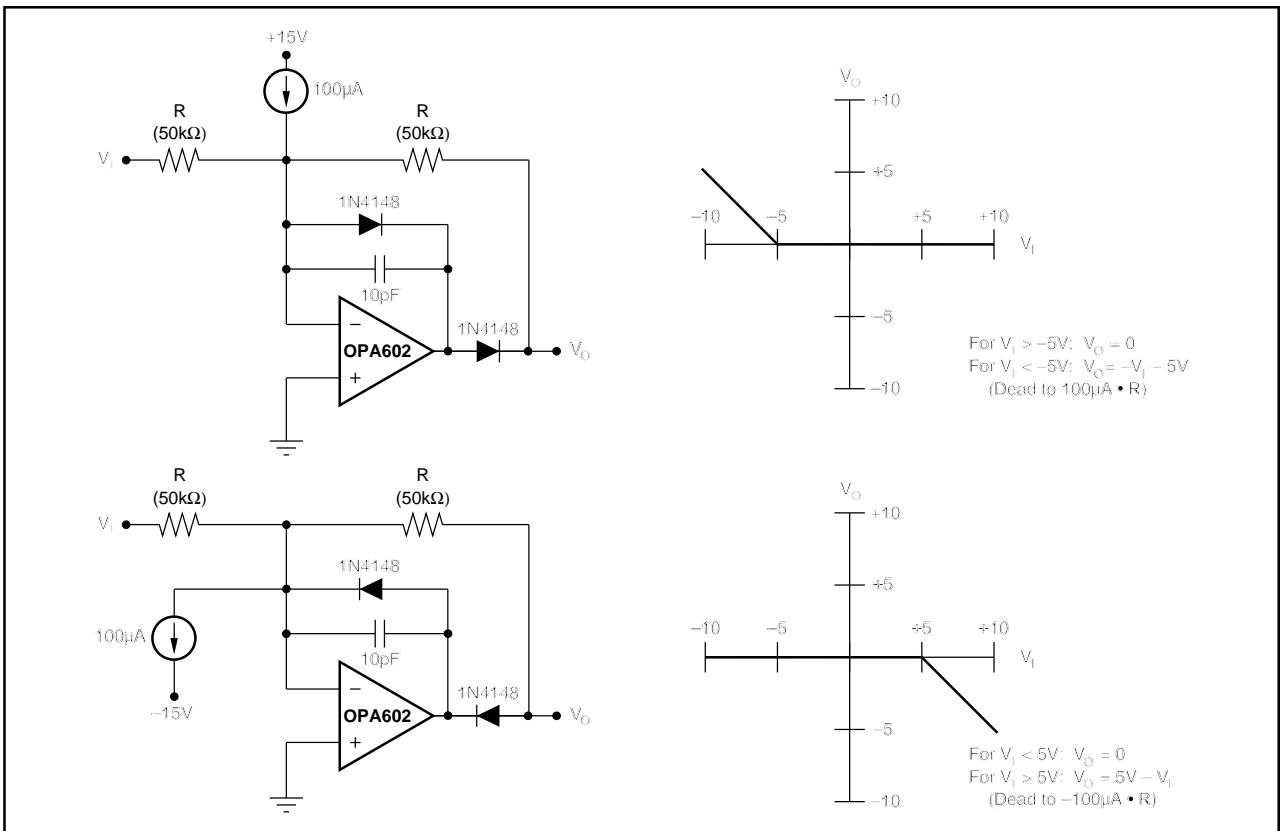

FIGURE 19. Dead-Band Circuit.

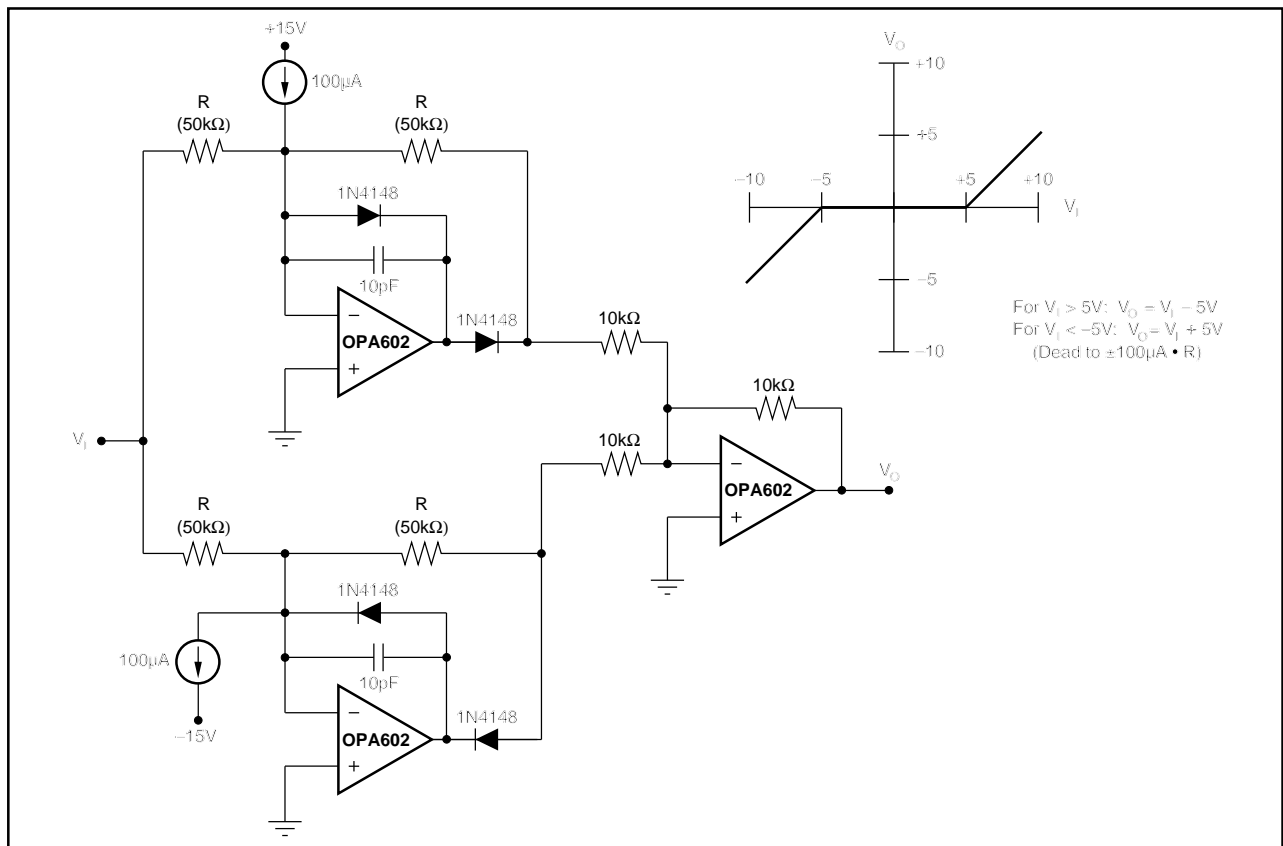

FIGURE 20. Double Dead-Band Circuit.

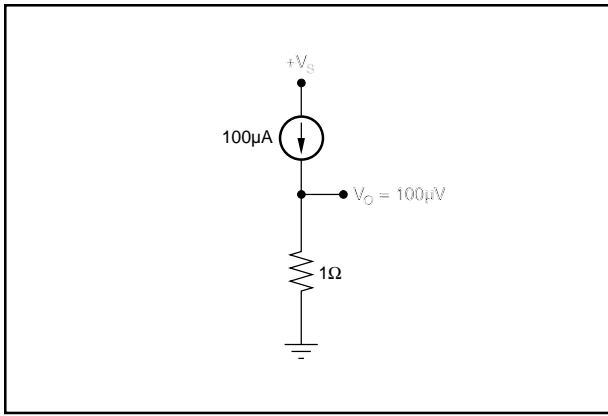

FIGURE 21. Low-Voltage Reference.

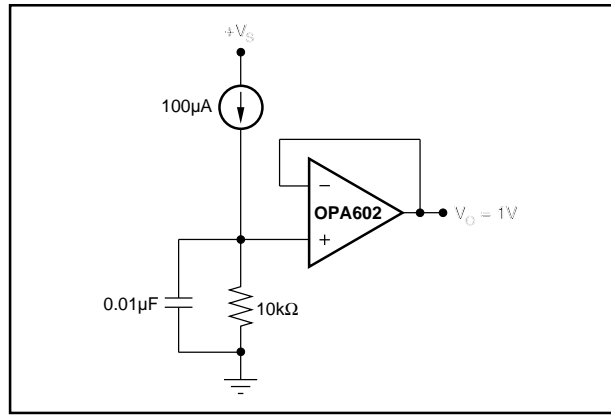

FIGURE 22. Voltage Reference.

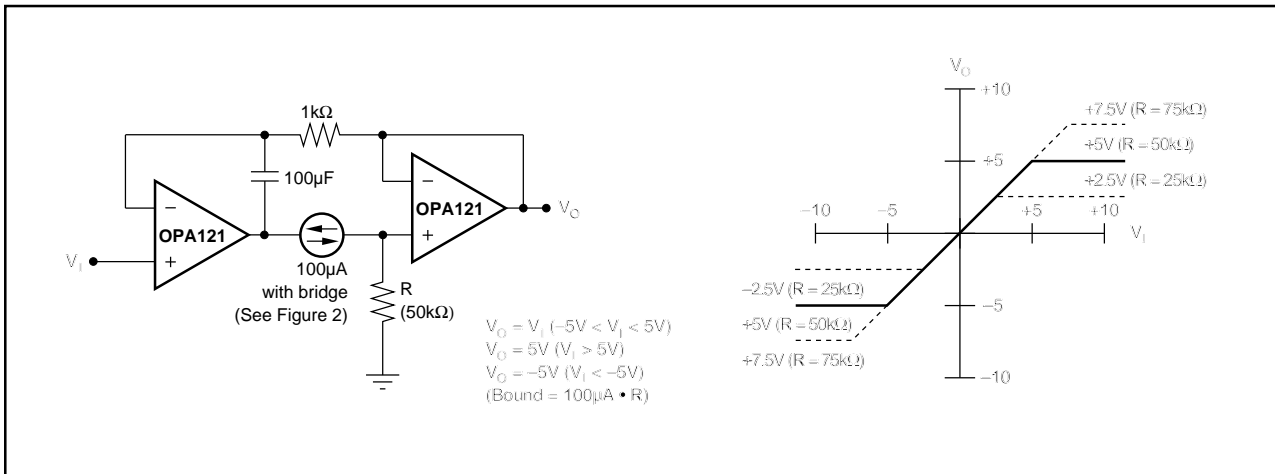

FIGURE 23. Bipolar Limiting Circuit.

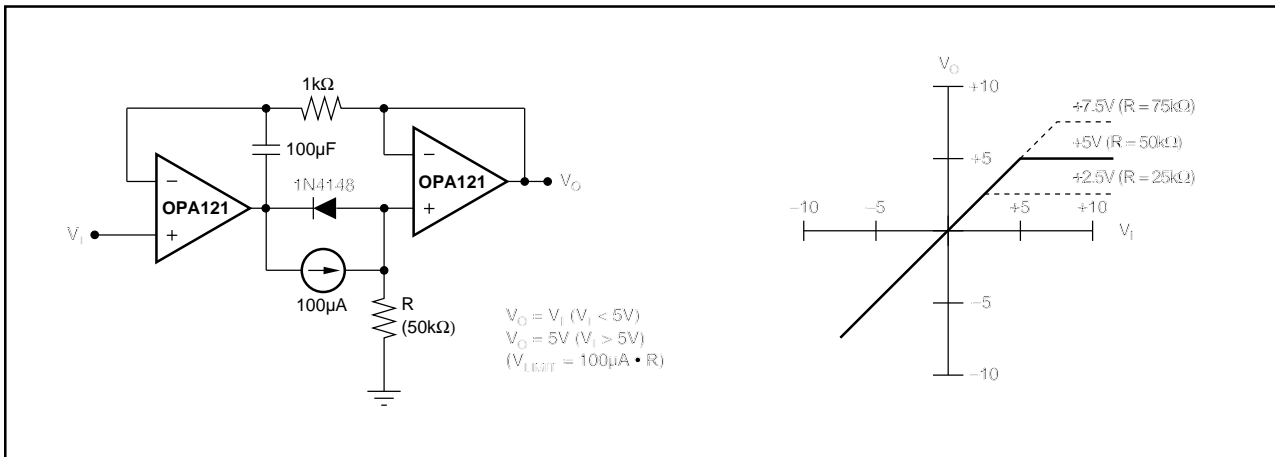

FIGURE 24. Limiting Circuit.

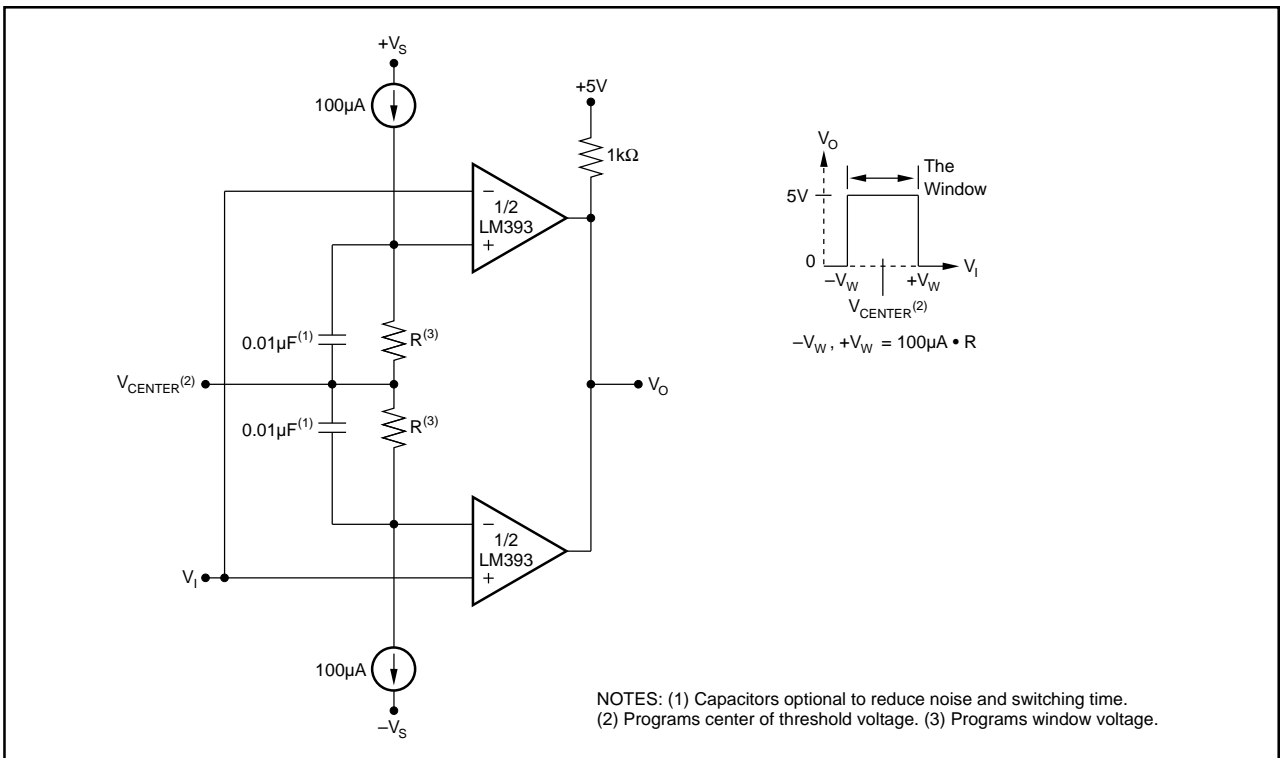

FIGURE 25. Window Comparator.

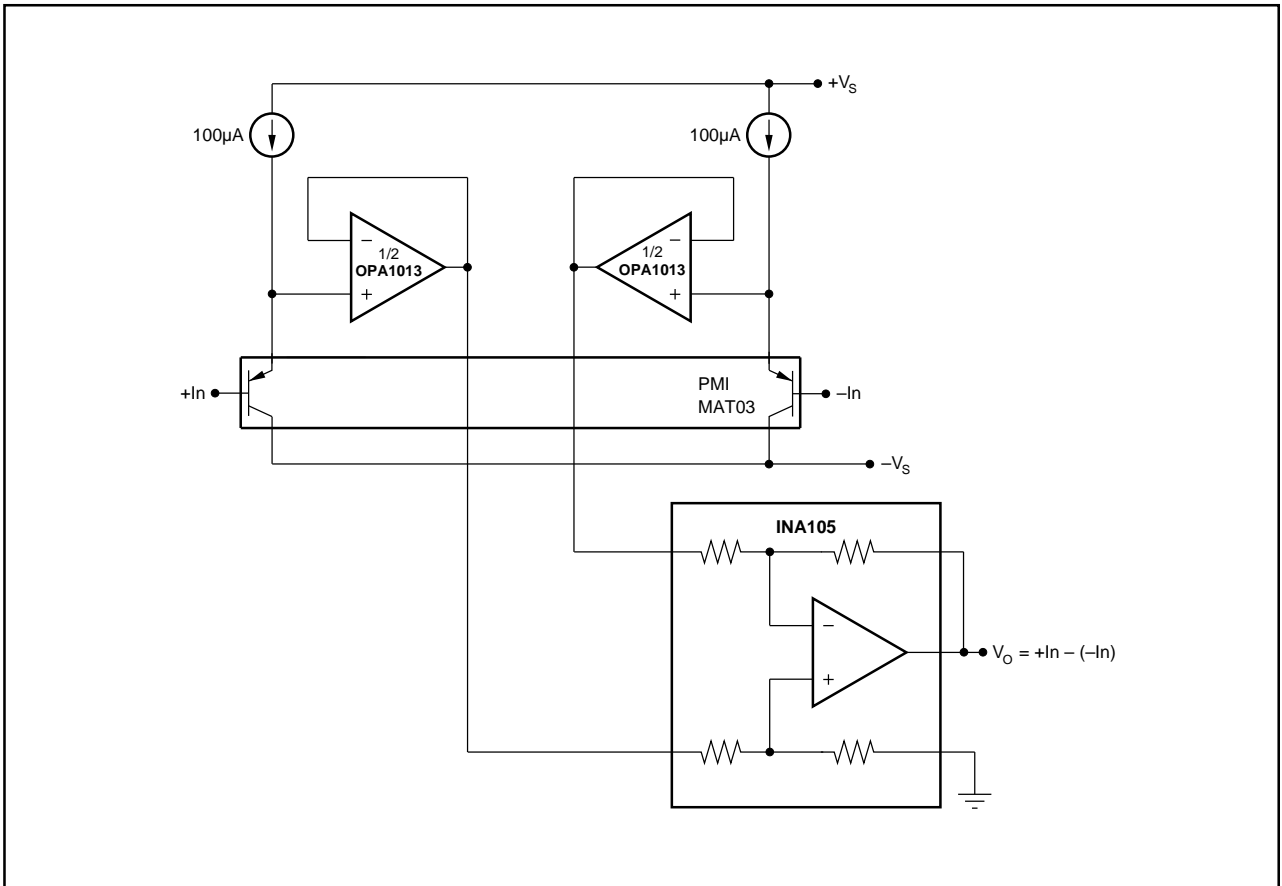

FIGURE 26. Instrumentation Amplifier with Compliance to $-V_S$.